

# Insolroll Dual Motorized Window Shade Fascia Systems

## Slim Dual Fascia System

Most solar screen and blackout fabrics work with 1 1/2" tube for sizes up to 8' wide OR 10' high.

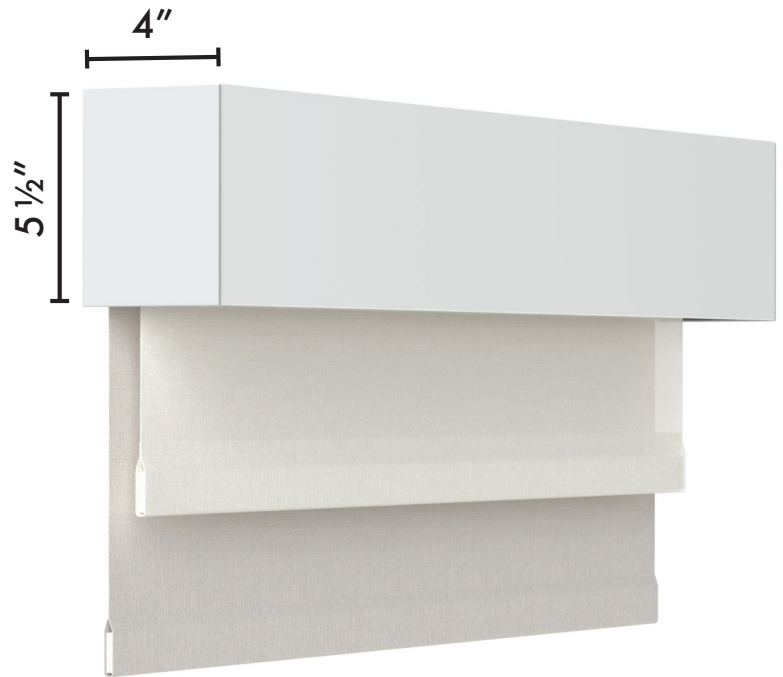
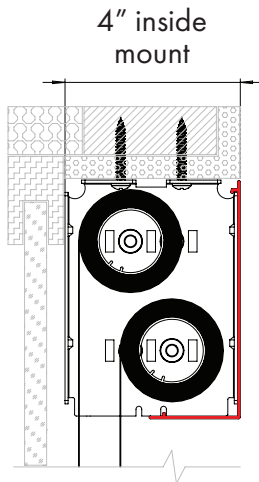

## Medium Dual Fascia System

Accommodates most screen and blackout fabrics with 2" tube on sizes up to 10' wide OR 14' high.

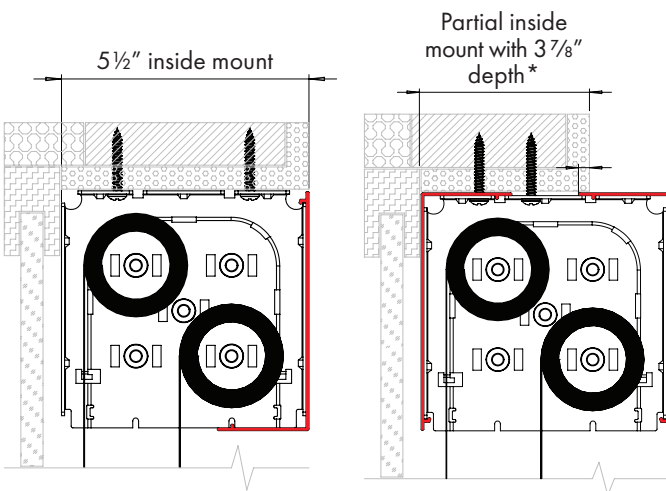

\*Fascia can be flipped to create Top/Back Cover and reduce light leak through top corner of shade on partial inside mount.

## Tall Dual Fascia System

Accommodates most screen and blackout fabrics with 2 ½" tube for sizes up to 11' wide OR 16' high. Can be coupled.

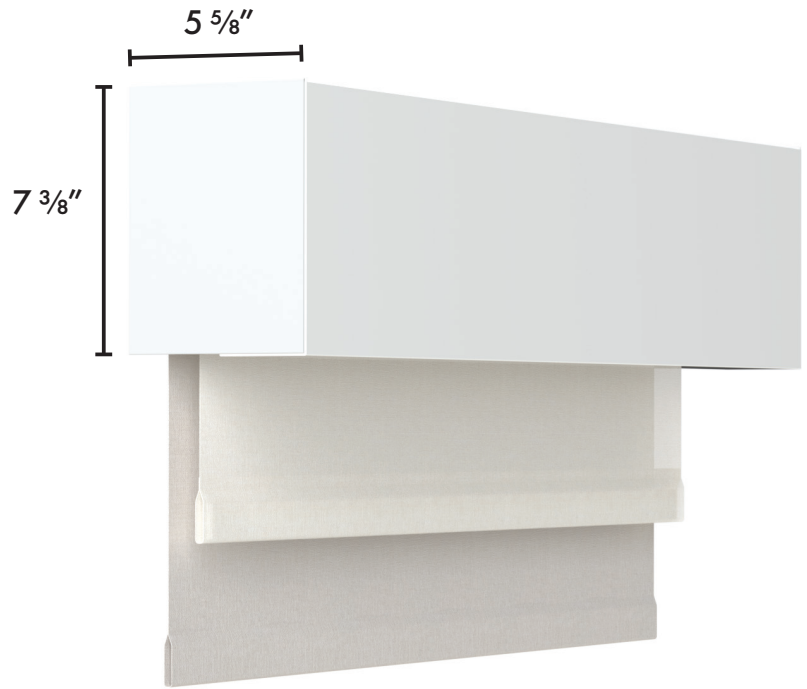
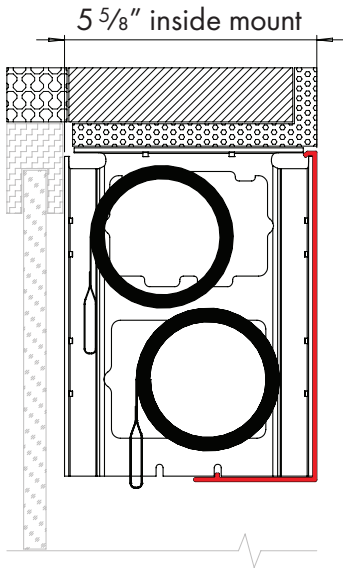

Model	Dimensions	Motors	Tube	Colors
<b>Slim Dual Shade System</b>	4" projection by 5 ½" height	<ul style="list-style-type: none"> <li>• BAT-L1</li> <li>• BAT-X1</li> <li>• BAT-L2</li> </ul> <ul style="list-style-type: none"> <li>• IQM-DCR</li> </ul>	1 ½"	White, Black, Clear Anodized, Bronze
<b>Medium Dual Shade System</b>	5 ½" projection by 5 ½" height	<ul style="list-style-type: none"> <li>• BAT-X1</li> <li>• BAT-L1</li> <li>• BAT-L2</li> </ul> <ul style="list-style-type: none"> <li>• IQM-AC2</li> <li>• IQM-ACR2</li> </ul> <ul style="list-style-type: none"> <li>• IQM-DCR</li> </ul>	1 ½" or 2"	White, Black, Clear Anodized, Bronze
<b>Tall Dual Shade System</b>	5 ⅝" projection by 7 ⅜" height	<ul style="list-style-type: none"> <li>• BAT-L3</li> </ul> <ul style="list-style-type: none"> <li>• IQM-AC</li> <li>• IQM-ACR</li> <li>• IUQ-AC</li> <li>• IUQ-ACR</li> </ul> <ul style="list-style-type: none"> <li>• IUQ-DCR</li> </ul>	2 ½"	White, Black, Clear Anodized

Note: Measurements are approximate. For exact dimensions please refer to the architectural drawings.

