



# INSOLROLL MOTORIZED SHADE

110 V AC Motor Shade Panel configurations



**Single Panel  
Non-railroaded  
Shade**

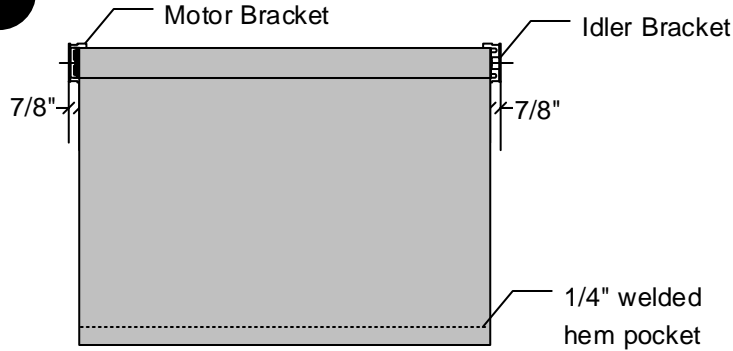

**Single Panel  
Railroaded  
Shade**

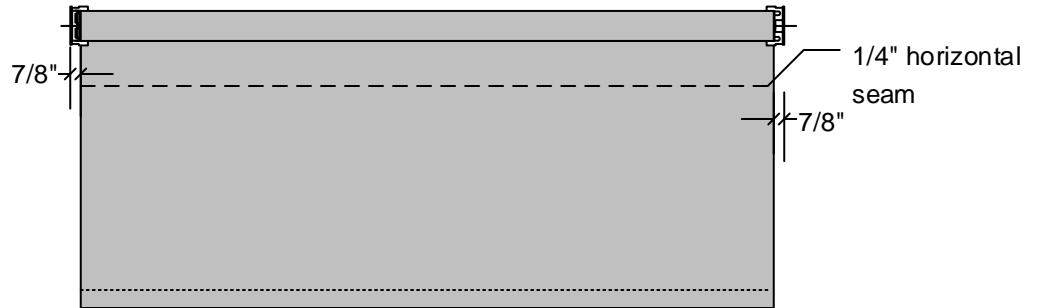

**Multiple Panel  
Non-railroaded  
Shade**

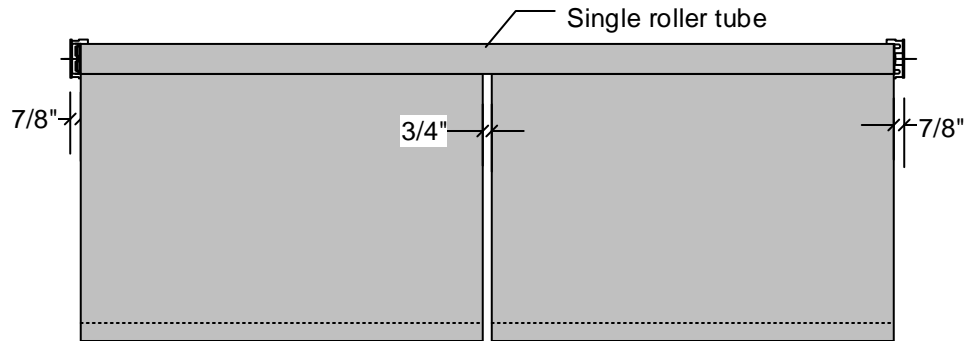

**Coupled Panel  
Non-railroaded  
Shade**

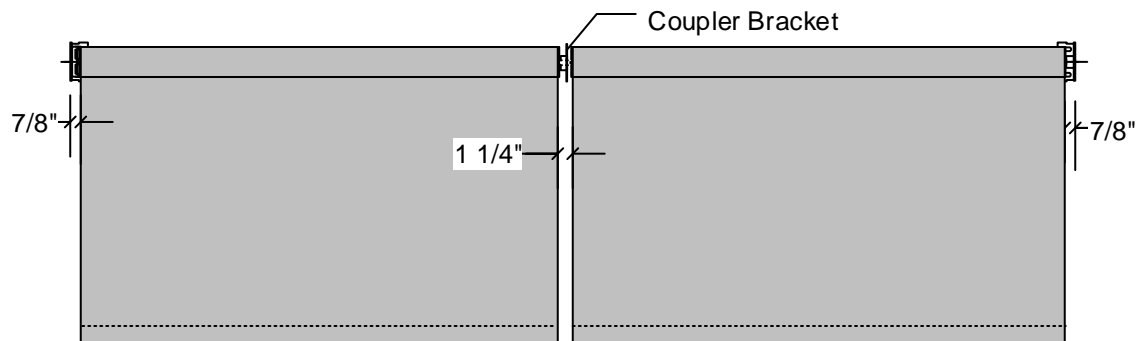

**Notes:**

1. Insolroll Shades with 110 V AC Motors (IQM-AC, IQM-ACR, IQM-485-AC, IUQ-AC, IUQ-ACR, IUQ-485-AC) are complete UL Listed systems with a 10' SJT rated pigtail and include a UL Listed label on roller tube.
2. Optional decorative end caps will add 1/16" to fabric gap for exposed and 1/8" to fabric gap for fascia on each bracket.